

# WHR and WHR-DS

2" Solids Handling Sewage Pumps,  
Single and Double Seal

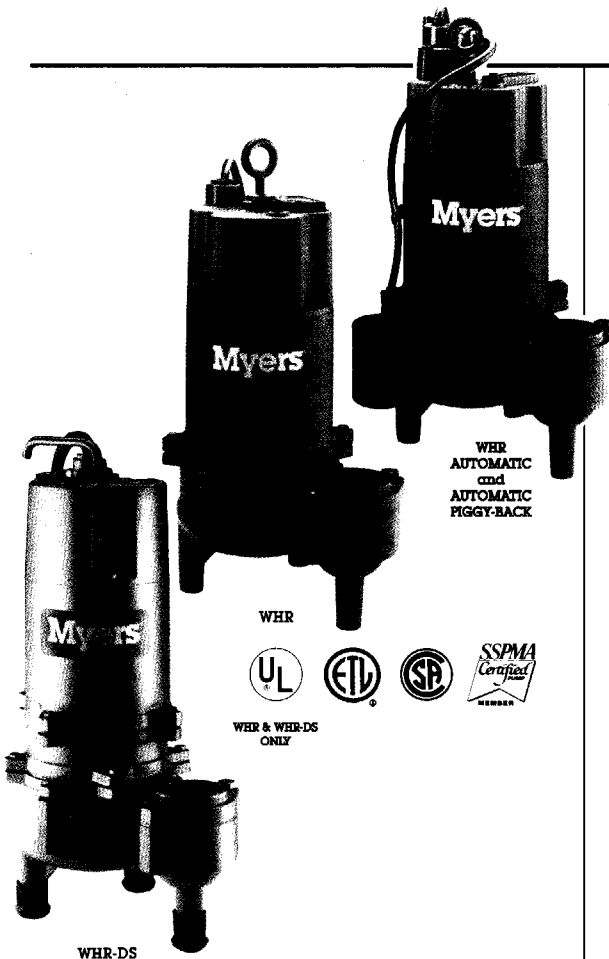

## ADVANTAGES BY DESIGN

### DURABLE MOTOR.

- Oil-filled for cooler operation and constant bearing lubrication.
- Single phase PSC motors have no starting switch to fail.
- Recessed impeller reduces radial bearing loads, increases bearing life.

### NON-CLOG OPERATION.

- Recessed vortex impeller passes 2" solids.
- Impeller operates completely out of volute passage.
- Passes stringy trash and other solids which conventional semi-open impellers can't.

### AVAILABLE WITH AUTOMATIC PIGGY-BACK SWITCH FOR MAINTENANCE-FREE OPERATION.

- Piggy-backed mechanical float switch allows pump to operate automatically or can be unplugged for manual operation.

## PRODUCT CAPABILITIES

Capacities To	175 gpm	662 lpm
Heads To	33 ft.	10.1 m
Solids Handling Capacity (dia.)	2 in.	50.8 mm
Liquids Handling	raw, domestic and light commercial sewage	
Intermittent Liquid Temp.	up to 140°F	60°C
Motor	1/2, 3/4, and 1 HP, 1750 rpm	
Electrical	1/2 HP, 115V, 1Ø, 60 Hz, PSC 1/2, 3/4, 1 HP, 230V, 1Ø, 60 Hz, PSC 208/230/460/575V, 3Ø, 60 Hz	
Acceptable pH Range	6-9	
Specific Gravity	.9-1.1	
Discharge, NPT (Optional)	2 in. 3 in.	50.8 mm 76.2 mm
Minimum Sump Dia. (Simplex) (Duplex)	24 in. 30 in.	609.6 mm 762 mm

**T**HE WHR SERIES PUMPS ARE DESIGNED FOR USE IN LIGHT COMMERCIAL AND RESIDENTIAL RAW SEWAGE APPLICATIONS. WHR pumps will pass a full 2-inch sphere. The recessed vortex impeller provides an unobstructed passage in the volute case which allows these pumps to handle stringy, trashy solids without plugging the impeller. The vortex impeller also greatly extends the pumps' bearing life. Available in double seal configuration for extended motor life. For more information, call your Myers distributor, or the Myers Ohio sales office at 419/289-1144.

### Construction Materials

Motor Housing	cast iron	
Volute Case	cast iron	
Impeller	cast iron, vortex	
Power Cord	Single Seal 16/3, 20 ft., 1Ø 16/4, 15 ft., 3Ø SJOW/SJOWA	Double Seal 14/4, 15 ft., 1Ø 14/3, 20 ft., 1Ø L/D 16/4, 15 ft., 3Ø L/D
Mechanical Seal (Optional)	single type I, carbon and ceramic or double tandem, carbon and ceramic	
Pump Shaft and Motor Shaft	416 SST	

WHERE INNOVATION MEETS TRADITION



# WHR and WHR-DS

2" Solids Handling Sewage Pumps,  
Single and Double Seal

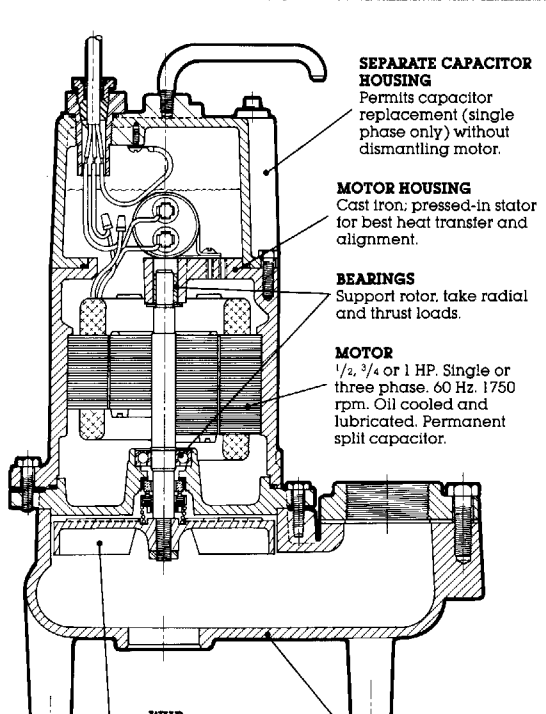

**IMPELLER**  
Recessed completely out of volute passage.

**VOLUTE CASE**  
Cast iron with support legs. Passes 2" solids.

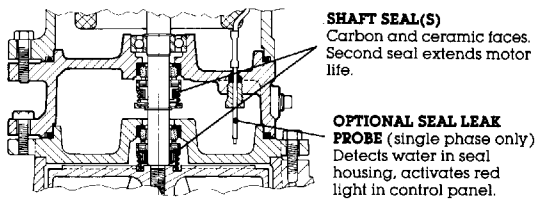

## DIMENSIONS

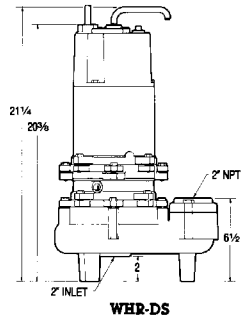
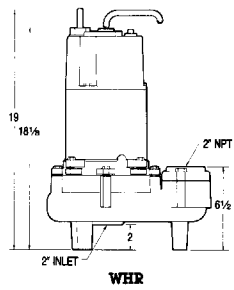
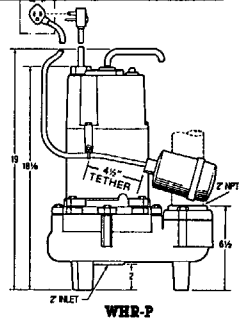
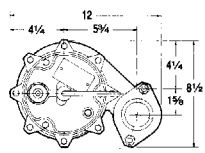

## PERFORMANCE CURVE

